



April 2023 Membership Meeting, News and Other Things

Typically volatile weather for spring. Remember the year there were no apples? Trees budded, bloomed and then came the freezing rain that killed the apple crop for the year. Not this year, so far anyway. Instead, the opposite - 80's and humidity thrust us into the midst of summer for a few days anyway. Reason enough for the sailboat racing contingent of the club to get excited and on the water. It was also a typical blustery spring day. On the south pond Kevin Kavaney gives the racing wrap up of the DF 95 boats with the B (smaller) sails that the boats were changed over to for windier days:

5 silly (better=excited - JB) guys decided to risk damage to our sailboats today by sailing in horrible winds that changed direction and intensity like every few seconds. 2 rig failures and both at the same spot - jib jack for lack of better term. I had the same failure last year from huge wind gusts like we had today. I'm thinking I will try to use a fishing swivel in place of the line under the eyelet...acts like a knife. Anyone know their dimensions from bottom of jib boom to the eyelet the line goes through?? Need to find pretty short fishing swivel to replace that fragile line. I lost an hour of sailing today because of this same failure. This is no diss to the 95...it was super brutal today and probably 100 percent of ODOMs would have likely been damaged in today's winds.

The warm spurt of weather got others into action too. Burt Fisher took his beautifully made buoys home for some minor repair and a good cleaning, and Kevin also manufactured a bracket for the count-down timers that Rob Segal made to replace the models no longer available. Rob's timers were featured in the January Newsletter. The bracket will fit into the top board on the floating dock at Smith Park in Bloomington where the group races (depending on the wind direction. The south pond with north-south winds, Smith all other). The discussion on the ODOM forum:

This is the Godzilla Starter Box that Robbie built for the club. It is much bigger and heavier, and of course LOUDER, than the one I bought from Dave Ramos which is way too quiet - at least for my bad ears. I machined up the aluminum sides so I could stage the starter directly over the big round dowel that goes into the holes in the Smith Dock...the original bracket had the starter either way too

far forward or back and would, I think, lead to an eventual dunk in the pond which would prove quite difficult to find in the muck... to say nothing of the damage the water would do to the electronics on board.

NOW if the damn weather would just get back on schedule...

Kevin



Rob responds:

As an FYI, the volume can be adjusted on these. Remove the indicated screw (yellow arrow) and you can access the little potentiometer on the board with a jeweler's screwdriver. I have them currently at about 1/3 to 1/2 of the possible output- I wouldn't turn them up much more than that unless we swap out the speaker with one of higher wattage.

As for the Godzilla nature of the build, I've spent the last 23 years making stuff for children's museums. Godzilla is my default setting. The destructive power of children (of all sizes.....) is amazing.

Rob

And finally:

Old clumsy men like me can be hard on equipment as well, so good thing you build things so well Robby..thanks again.

Kevin

At the Meeting

Before the meeting a couple of members just could not resist running on the water:



That is Dave Brinkman in the foreground and Doug Johnson in the green hat.

A sneaky meeting this time. Five minutes to seven and a nice group, I brought the tug from last meeting back for a follow up show and tell and that was it. I said to the group “looks like a light meeting tonight”. Nope! The group (actually a few more showed up after this photo by Richard Dahlquist):



Just a few announcements:

- Rob Segal reported that he received enough interest for all four classic boat shows that he can commit to the show organizers that the club will be there.
 - + Saturday, June 24th, White Bear Lake
 - + Saturday, July 8th, Alexandria
 - + Saturday, August 26th, Gull Lake
 - + Saturday, September 9th, Lake Minnetonka
- The Spring Coffee get-together is on!! We have numbers in the twenties right now and I expect that we will have over thirty participants when it happens this Saturday, April 29th, at the Hughes Pavilion, from 10am to noon. Please feel free to drop on by even if you have not signed up, but it is always nice to know that you are expected so even if at the last minute let Terry know at. Bring a boat!

Show and tell:

First up was Glenn Davis who brought several issues of the magazine Scale Ship Modeler from 1993 and 1994 in which the EMYC, and Centennial Lakes Park, had been prominently featured.

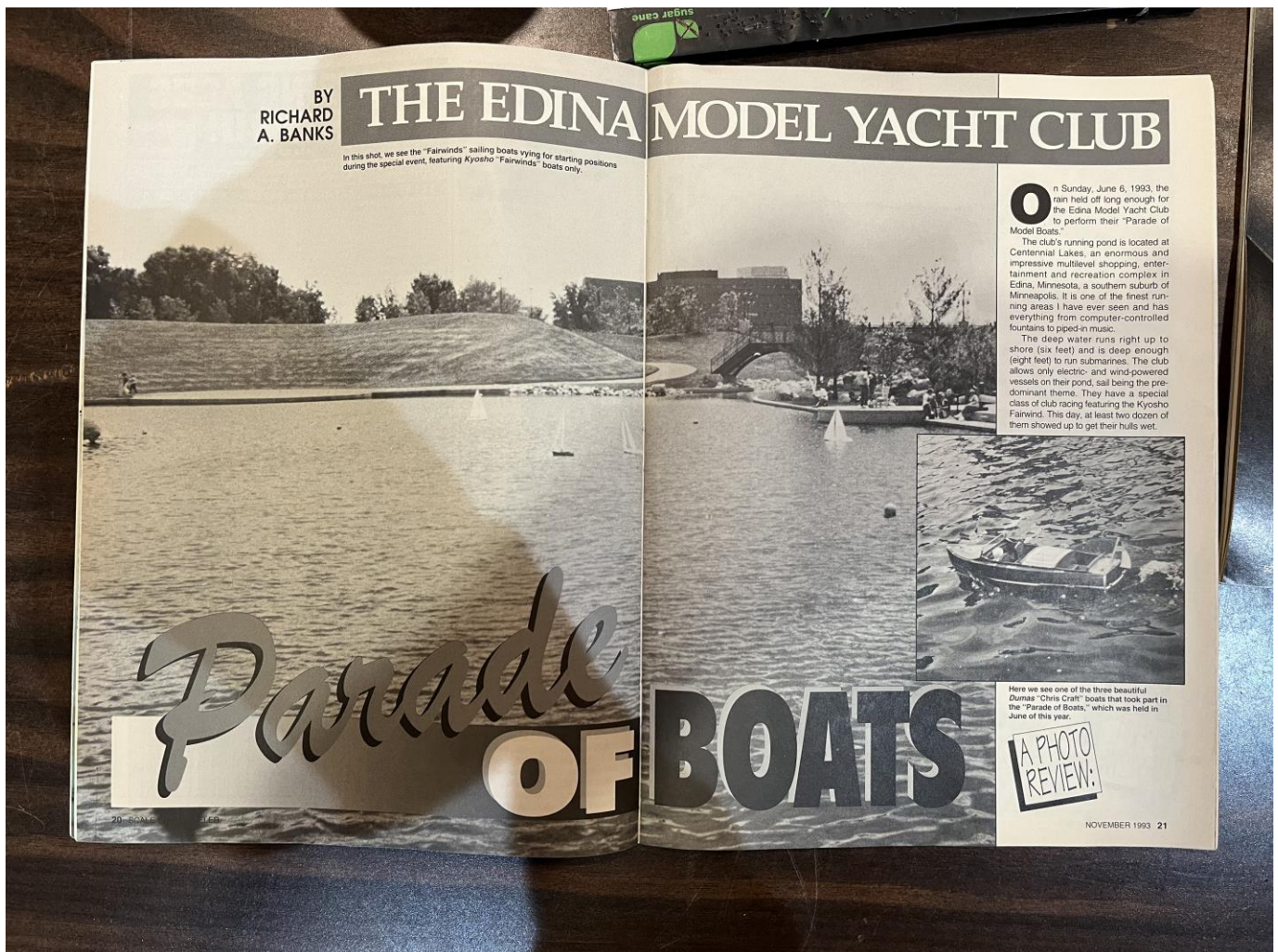

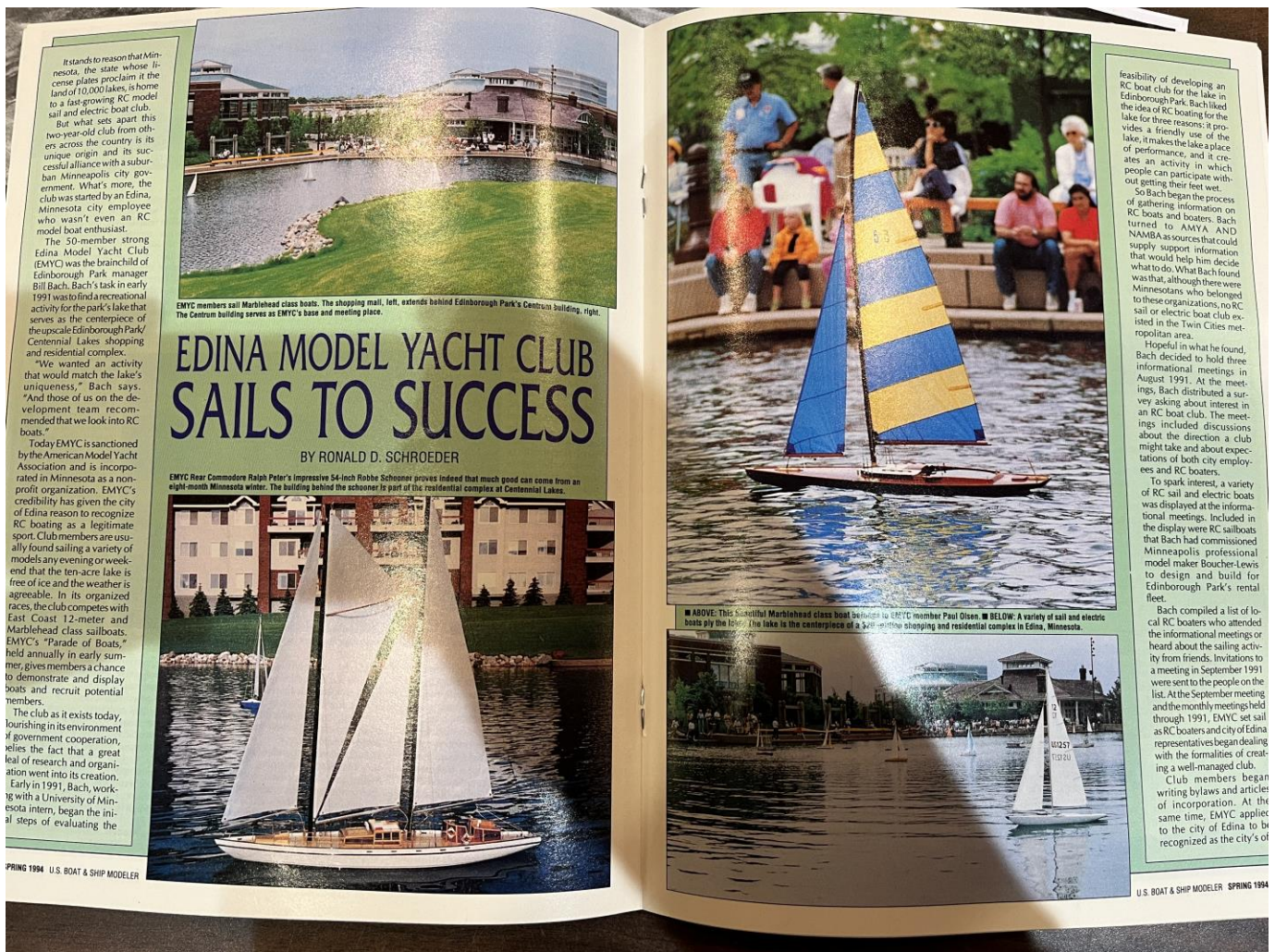

Early photos of the park before all the buildings were in place are always interesting! One of Paul Olsen's Marbleheads is featured prominently in the blue and yellow sails (every one of the over 40 built are true classics!), and also Commodore Ralph Peter's Robbe Schooner. The schooner was offered to club members a year ago with no one expressing any interest (!?!).

Next was my tug from last meeting.



I have mentioned before that you are very fortunate if one of the great craftsmen in the club takes an interest in one of your boats, or gives a helping hand, or in this case takes pity on your meager effort to show you how it **should** have been done! The problem was both of my Aqua Craft boats had lighting, but it was very faint from the separate 2 - AA battery pack. My solution was to take a 4 - AA pack and jump over one battery to just use three AA's. That is (3 x 1.5 volts=) 4.5 volts versus the original 2/pack (2 x 1.5 volts=) 3.0 volts. It was a nice improvement, even if as John Bishop noted a little too bright. I am a fan of making things work within your own limited abilities and using what you have at hand in your shop (such as it is), but John offered to show me how it should have been done and said I could bring the boat over to his house. What he wanted to do was add a voltage regulator in place of the AA battery pack, thus allowing all electrics to run off of the main battery for the motors. Really neat. John is meticulous in everything he does and sent this ahead of our getting together so I could understand what was proposed:

Yes, we would hook it up to the main battery and then reduce the voltage to our liking. With the (voltage regulator) unit that has the digital display, we can select to have the display read either the main battery or the reduced voltage by toggling a small switch. It therefore acts as a voltage meter to show you the main system battery voltage as well. Again, the unit can operate with or without the display illuminated. It's a really slick little device-all solid state, surface mounted components.

*Think of the voltage regulator as a faucet-we can set the **output** voltage anywhere from full unrestricted voltage (full flow) to highly reduced voltage (trickle) similar to how a faucet handle works. What's nice is that as the main system battery voltage fluctuates during its use, the output voltage remains constant and unchanged, hence **regulated**. That way when you run the boat wide open or run at a slow crawl, the lights appear to be uniform and consistent in their illumination.*

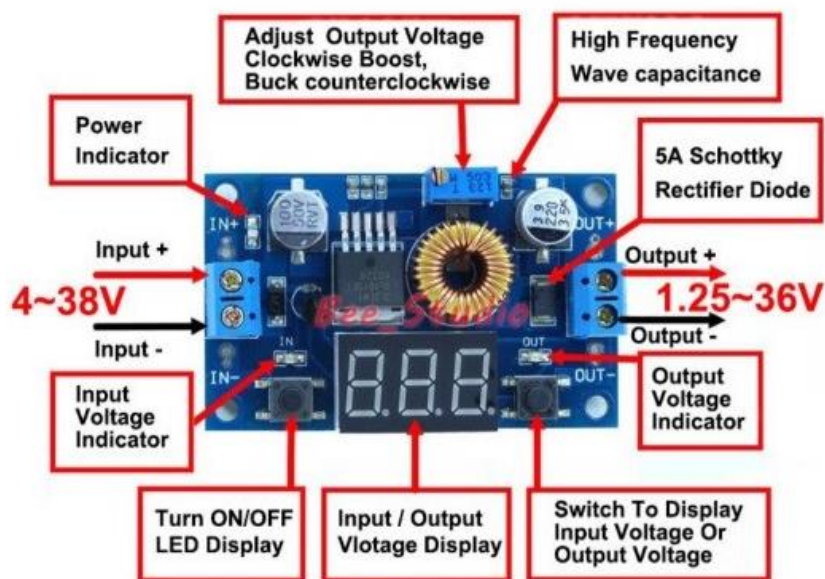

EBay link: <https://www.ebay.com/itm/383737532594> (Price is only \$6 - \$9 plus \$6 shipping!)

At John's house, we descended to his shop area. It was of course, beautiful, immaculate, and very functional. Here is the main bench area only:



Note the classic Marantz receiver in the upper wall area. John collects those and I also have one in my shop in the garage. Mine is in great condition too but not as fancy a model. We started at 2:30 and finished after 7:00! Re-did some of the wiring, added a switch, repaired a broken connection to one LED, replaced another (and had to add a resistor for the new LED to have the same intensity as the originals). Easy to say, the time involved says it wasn't that easy. Completely redoing the wiring in the mast was a four hand requirement! Inside a narrow, plastic (! watch out with the soldering tool!), channel, was actually nerve wracking!



The other side....



And the finished product:

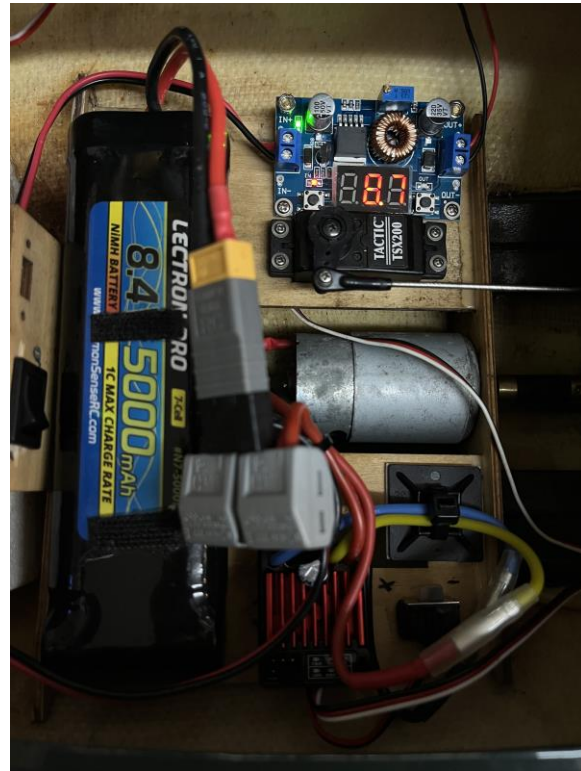

There was no anticipating how nice the lighting would be, and how even the intensity. At the meeting when I turned on the lights there were several “ohhh’s and ahhhh’s”, it really was incredibly nice! But John was not done yet. Remember meticulous? Jeff McCabe brought a present for me from John:

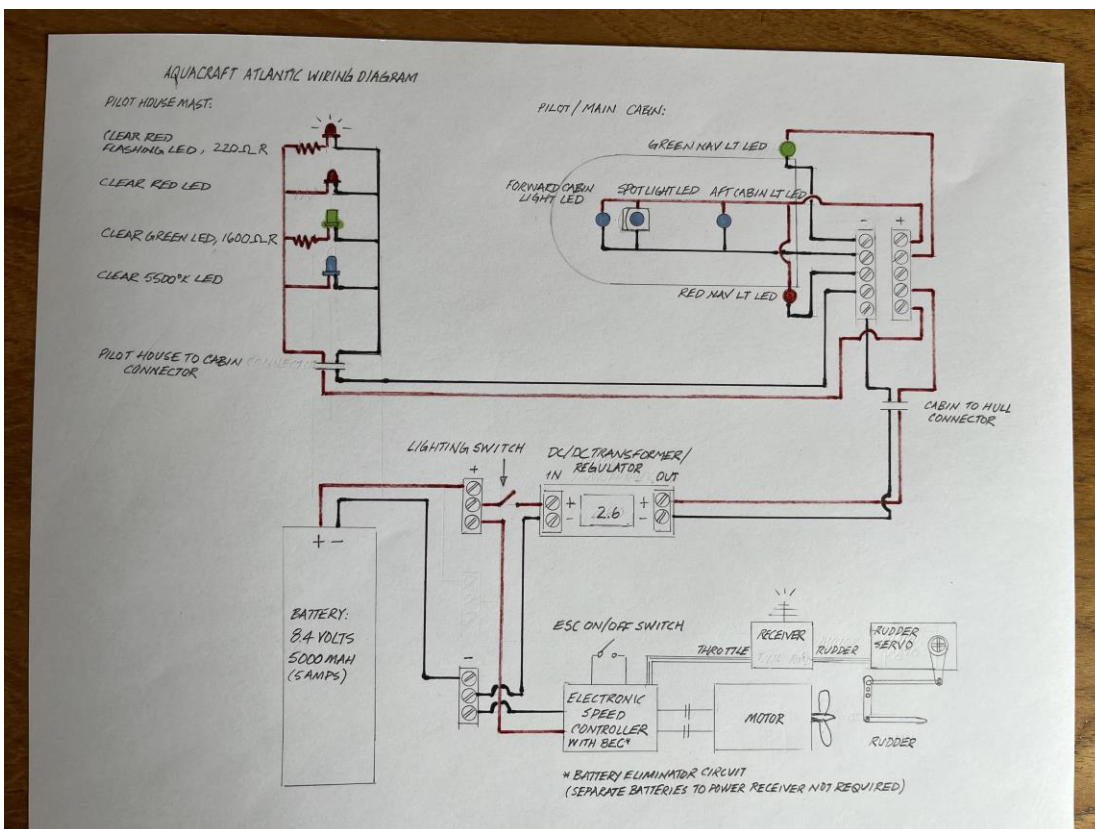

All hand drawn, and as a person who prepares construction plans for a living I can tell you this is really, very, very nice work, and has the quality of not being computer generated. Very grateful for the help (really he just let me help), and the lasting record.

Next up was James Kloss:



This was his first time build effort, still has a bit to go to complete the model, but everyone appreciated what James had achieved, and he got enthusiastic applause for what he had accomplished and an appreciation for bringing it to share will all. A very handsome model. If you can attend the Parade of Boats the Builders Corner is manned by Dick Walker. Dick explains to all that modeling is something that you take on and don't expect perfection the first time. But each new model is better, and better than the previous and we all learn as we go. James' journey has definitely begun.

Rob Segal has taken to ODOMs along with all his other boats, and is the consummate model builder of multi talents. So what is a person like that to do with a cracked hull, expensive and unreliable replacement from the class official supplier? Build your own mold of course!



Of course expertly done, and Rob reports that the deck was by far the most difficult to replicate. Some parts, as the keel assembly, have been ordered from the official AMYA approved supplier. It will be interesting to see the final product when it is all finished! When completed it will meet all the requirements for the class.

Kevin Kavaney brought a runabout in which he has replaced and upgraded the motor. A nice installation by Kevin as usual and includes a water cooling jacket:

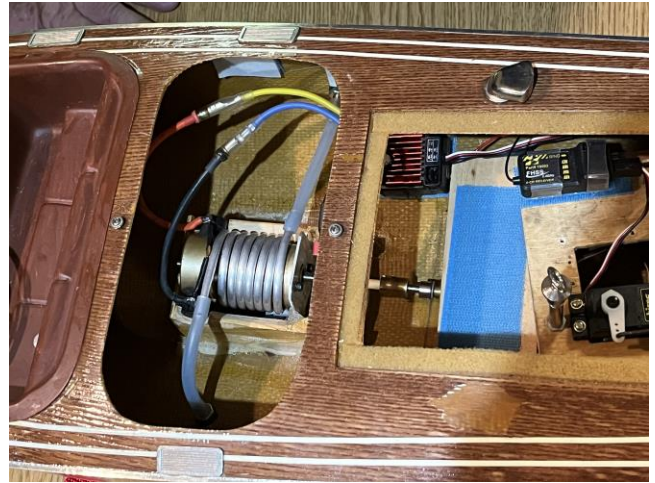

And final presentation was by Paul Wyatt with his Whitby Abbey ship:

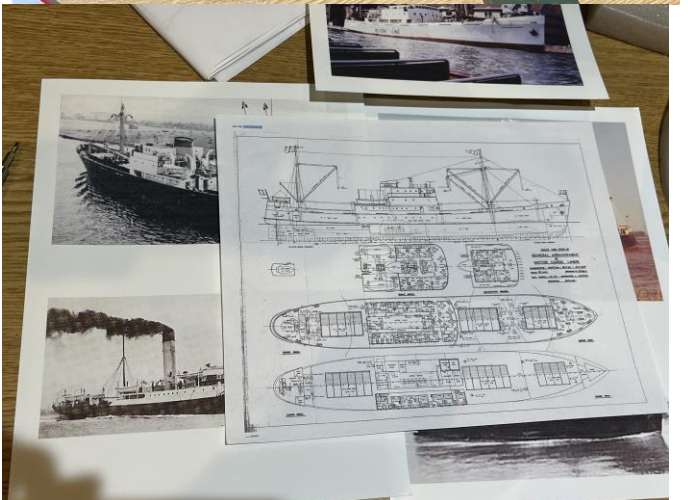

Most impressive is that Paul constructed this boat from scratch with the photos and the plan in the above right. He blew up the plan to the scale he was building and it went from there! A very excellent job!!!

This meeting had a great variety of projects for the modest to the very skilled builder. All boats will need work at some point, and it is always nice to be able to do the work yourself, or have others lend a hand. It is the spirit of the club and there is great satisfaction in helping out someone else. Be generous with whatever talent you have - there is always someone with more, or less, than you have. And for all, don't be hesitant to ask for help. We offer it to non-club members, and we certainly are willing to share with those that are members.

Coming up:

- Spring coffee and pastries, Saturday, 10:00 am, Hughes Pavilion, April 29th
- Membership meeting Tuesday, May 16th, 7:00 pm.

A final reminder for most, and information to the newer members that the club has three forums you are encouraged to participate in (plus there is FaceBook):

EMYC forum is hosted by Gary Tschautscher, and is for general communication between members. Often used to see who is planning on going to the ponds during the summer.

Gary also hosts the forum for the ODOM racing sailors. This gets heavy usage during the racing season and beyond. Useful for participants and for those that just want to come and watch. Get in touch with Gary at.

There is a similar forum for the DF 95 sailors and racers, hosted by Burt Fisher. Contact Burt at.

John Bertelsen
Commodore
Edina Model Yacht Club

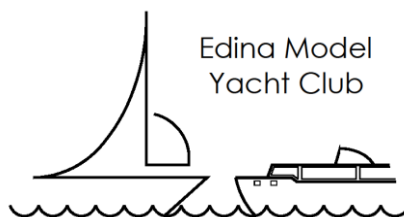

Vice Commodores: Gary Tschautscher, Rob Segal, David Brinkman
Treasurer and Membership: David Brinkman
Sailboats: Tony Johnson
Scale Modeling: Kevin Waldo
Website: David Petrich
EMYC and ODOM Forums: Gary Tschautscher
DF 95 forum: Burt Fischer
Dry Dock Party, Spring Breakfast: Terry Bertelsen, Julia Moen
Face Book: Richard Dahlquist, Todd Moen
Off site events: Rob Segal