



SAIL & SCALE

NEWSLETTER OF THE EDINA MODEL YACHT CLUB

April 1996

Volume 5, Number 4

Commodore's Corner: My thanks to Dave Bros for inviting March's guest speaker, Jim D'Agostino talked for about one hour and was well received by the membership. Questions and answers on building techniques followed.

John Bishop has agreed to reschedule his discussion on electronics for our April meeting. John, with all his charts and marker boards will answer those electronic mysteries for you.

Fast electric boats will also be discussed by Dan Proulx and Doug Campbell. They will try to explain why it is so much fun to drive so fast for so short a period of time.

April 27th marks the club's first official event. The ice will be out and we will set the buoys for a fun filled '96. Start recharging those batteries, tuning those sails, and if you are like me, dusting off your boats. I'm ready for the season to begin!
Jeff McCabe

Note: More than half of the group has now forked over their ten bucks to extend membership until year's end. The next (May) newsletter will be your last if you have failed to pay-up.

Where's The Meeting?: Centennial Lakes Centrum.

What's The Meeting?: As a result of our guest speaker last month, the discussion of radios and electronics did not occur. Our apologies to the several members who made an effort to attend specifically for that talk...and were disappointed. John Bishop has agreed to pick up the gauntlet at the April meeting.

Fast Electrics remain on the agenda. Find out *watt* the deal is with this segment of our hobby. Items covered will be hull types, drive trains, batteries, speed controllers and an *amplitude* of details. Dave Ulmer will give a dissertation on how to be number two on the pond (just kidding, Dave!).
Dan Proulx

What's Comin' Up?: Throughout the boating season, we will attempt to keep you up to date with the publication of the current month and next month's, "Schedule of Upcoming Events" (see page 2). Please call the editor if you come across any nautical happenings which may be of interest to members. It's obvious that..."You can't go, if you don't know!"

Marblehead Class Regattas: Marblehead sailors please note on your calendar the following Sundays for regattas at Centennial Lakes: June 23rd, July 14, August 18th, from 5:00PM until 6:30PM These dates and times may change depending on weather and

input received from the first regatta. Start tuning your boat for a fun time.
Mikio Kirihara

Typical Of A Modeler: Roy Brandhurst of the St. Louis Admirals has kindly consented to allow us to reproduce some of his sketches of ships fittings. A couple are contained in this issue. They'll be appearing in our publication from time to time. Thanks much, Roy!

Toys Ahoy! The toy boat show will take place again this year at the Hopkins Eisenhower Community Center on Saturday, April 20th. (8AM until 3:30PM)

Honking Geese: Tom Shirley has contacted the University in regard to the increasing numbers of Canada Geese at the pond. He was advised to "harass them" as the best way to discourage their presence. We have been asked to "do your best" to assist in that effort. Unfortunately, the beautiful lawn at the new croquet courts will probably attract even more birds.

Builder's Corner: We exchange newsletters with the St. Louis Admirals boat club (copies are in the file cabinet). This month, Tom O'Dell sent along plans for their club's "Battling - Polo Tug". This is a river tow type boat 18" long with 6" beam used for friendly competition such as team polo playing, ballon tag,, etc. Jeff McCabe will have copies of the plans at the meeting and I will have my boat at the May meeting. Looks like it could be fun!
Jim

Look Alive! I was sailing a borrowed boat last season when I lost radio control. I would like to request that anyone who spots an obvious "runaway" attempt to intercept it prior to wall impact. Thanks!
Bob Jester

Classified: I find it hard to believe that no one has anything to dispose of! ...George, Erwin, Gary??

Signs Of Summer?: Although you can't tell it by the recent weather we've had, Summer is just around the corner. Of course, with summer comes the biggest event the club holds...the Parade of Boats. June 9th is the date slated for this annual event. Several people have graciously volunteered their time to help with tasks. More bodies are needed to help out. Give me a call [redacted] to offer your services. Upcoming newsletters (only one left, Ed.) and club meetings will address the details as we get closer.
Dan Proulx

May Newsletter Deadline: May 7th. Thanks to Doug, Dan, Dave, John and Bob for their input this month.

Membership Meeting, 2/20/96: Jeff McCabe opened meeting informing members of an AMYA membership promotion. Jeff had AMYA information at the meeting on joining. Dan Proulx presented an update of the current posters that will be displayed at the local hobby stores. Final versions of the posters were passed around for members to see. Dan asked for support from members to maintain each poster by making sure the supply of cards did not run out. Several members volunteered to do so. Jeff reminded members that Dan is also heading up the Parade of Boats this June 9th, and to start looking for volunteers for helping with the event. Discussion was held on having next meeting's topic to be about electronics. Jim Smith brought up that he needs people to contribute to the newsletter as he is running low of ideas. John Bishop brought up that Jim is doing an excellent job with the newsletter and encouraged members to contribute. John also passed around a sign up sheet for 2 members to contribute an article each month. Business part of meeting was adjourned and discussion followed on building with foam led by Paul Olsen and Jeff McCabe.

Membership Meeting, 3/19/96: Commodore McCabe called the meeting to order at 7:05 PM. (33 members and guests, including all Board members were present). Dan Proulx discussed the Parade of boats. Asked for volunteers to sign up for different tasks after the meeting to help with the Parade in various ways. He mentioned an article will appear in the newsletter about the Parade. He will also have Parade of Boats posters available for April's meeting. Dan also had cards available to stock the EMYC posters at each hobby shop. Jeff McCabe asked for volunteer(s) to man a table for the Toy Boat Show this April. Jim Smith mentioned that sales are not allowed at the EMYC table because of our club status. Jeff McCabe asked that the newsletter list a schedule of events in each issue that will cover 2 months of events. Business part adjourned.

Doug Campbell



Schedule of Upcoming Events

	Every Sunday	Open Boating	4:30PM - 9:00PM
	Every Tuesday	Open Boating	5:30PM - 9:00PM
	Every Thursday	Open Boating	5:30PM - 9:00PM
April	16th	Membership Meeting	Centrum Bldg. 7:00PM - 9:00PM
	18th,19th,20th	Tug Boat Enthusiasts Conv.	New Orleans, LA 8:00AM - 5:00PM
	20th (Sa)	Toy & Model Boats Show,	Hopkins , MN 8:00AM - 3:30PM
	21st (Su)	Boating with the Toy Boats	South Pond 11:00AM - 2:00PM
	27th (Sa)	Ice Breaker and Buoy Setter	South Pond 1:00PM - 3:00PM
		(Note: This is a sailboat event too, Dick!)	
May	5th (Su)	All Boats Relay	South Pond 2:00PM - 4:30PM
	18th (Sa)	Big "E" Spring	South Pond 1:00PM - 3:00PM
	21st	Membership Meeting	Centrum Bldg. 7:00PM - 8:00PM
June	9th (Su)	Parade of Boats	Centrum Bldg. 1:00PM - 6:00PM

FIRE EXTINGUISHER

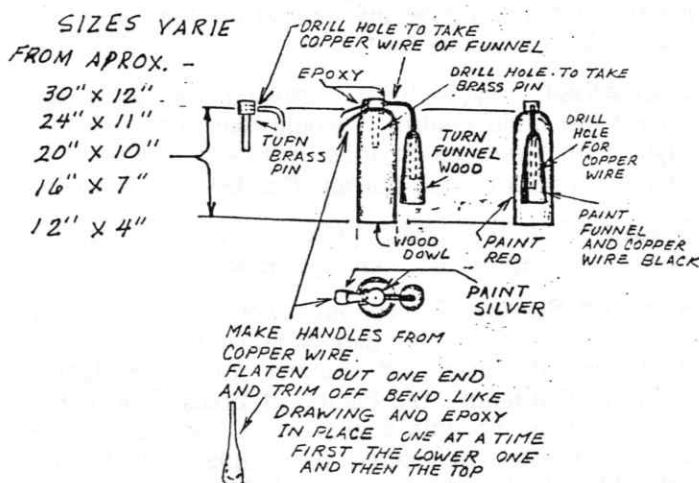

FIRE AX

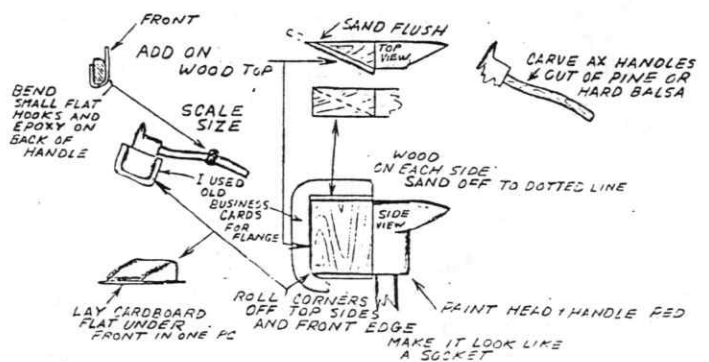

More on Glue: John Bishop and Dave Bros forwarded information on a new breed of Polyurethane adhesives which are marketed under names such as *Excel* and *Gorilla*. Although they are marketed as "100% waterproof" and "exceeding the minimum standards in all categories", an article in *Wooden Boat* magazine concluded: "...if the cost of urethane glue comes down...it may prove to be a quite useful adhesive for boatbuilding. But, we still need to explore long-term water resistance...". I'm really happy sticking with my old reliable, *West Systems* epoxy.

R/C Iceboating (or - what do you do in Minnesota when the ponds freeze?)

by Doug Campbell

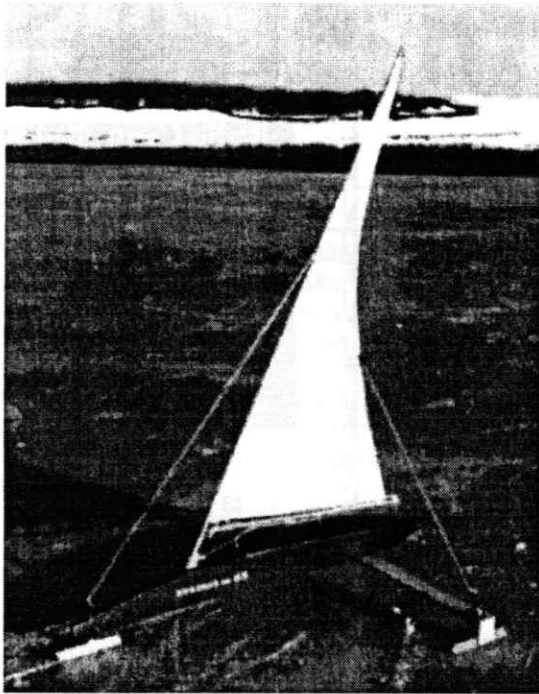

"NOKOMIS on ICE" at the north pond

As some of you already know, Tony Johnson has built a 1:4 scale version of a DN (Detroit News) iceboat. He has been sailing it around the north pond and at his home for a few years working out what works best in terms of blades and sail sizes, etc. The scale size is about 3 feet long. Chuck Bottemiller built one soon afterward, based on what Tony had worked out. Last winter, I started one from plans that Tony provided. Due to my typical schedule however, I never finished in time for the winter of '94-'95. This fall though I got in gear and finished it in time for the ice (with some help from Tony in a few significant areas - not the least of which was a sail). Mostly the building process was fairly simple, due to the shape of the "hull" or whatever it may be called. I used some of my supply of hoop pine plywood to make the hull and plank - the part that the rear ice blades bolt onto - consisting of laminated strips glued on a slight curve to give the boat some suspension or whatever.

The challenging part is what most modelers that scratch build come across - where to find parts or how to make them? Most items were available at the local hardware store. The mast and boom material were aluminum tube I procured at Ax-man surplus. The difficult item is making the front steering chock holding the front runner. Again, Tony came to the rescue here and silver soldered a chock together while I helped by holding the things straight. I finished mine off by laminating mahogany veneer to the hull, staining and applying West-System epoxy as a "varnish". I decided to give mine a name - mostly because I saw several pictures of iceboats with names on the side.

"Nokomis on Ice" seemed to fit because of living near Lake Nokomis.

Once the initial bugs were worked out - namely throwing away some totally worthless blades I made from stainless steel carving knives (not Chicago Cutlery, I assure you) and switching to some 1" x 1/8" cold rolled stock from the hardware store, cut at a very sharp 45° angle, things went great! Performance is effected basically by the same things that influence a real one; wind speed, ice conditions, weight of the boat, sharpness of the blades, sail design, etc. The boat will start out tame enough, but once things get hooked-up, look out! With the right conditions, it looks like it sails at about 30mph plus. I have yet to fully develop my skills at piloting - a few spin outs and snow bank plowing - no damage to the boat or any people however, although each trip to the pond I get better at it. That brings up the only cautious side to it. Boating with skaters on the rink - especially on a crowded weekend - is not recommended. There are far too many curious kids who can damage the boat or can be hurt by the boat by skating too close! Choose a time when it's far less crowded. That's been the case since the rink has closed but the ice is still pretty good. Then it's really fun! R/C Iceboating has a really unique allure for me. It's kind of a cross between R/C sailing, fast electrics, and I suppose R/C cars too. And it's easy to get the boat if you need too - just walk on water!

It Ain't Publisher's Clearing House, but: How are you at identifying boats? I thought that I'd include a few boat / ship profiles in the newsletter between now and the Dry Dock party. Each picture will be numbered to enable you to compile a list between now and November. The member who names the most correctly will receive a veery valuable gift at the party. The more specific you are, the better your chances. The answer: 'Battleship' would be acceptable, but 'USS Missouri' would be better... Unless, of course it's a picture of a submarine! Enough hints, already!

Let's begin the "Name The Ship" contest with:

#1:

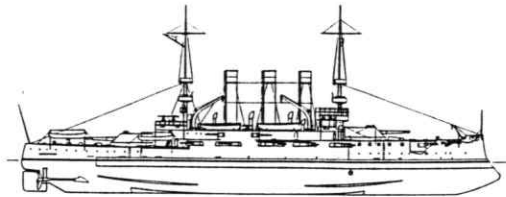

#2:

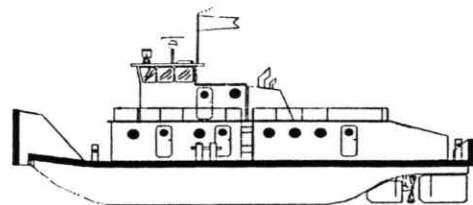

Building Tip: An easy way to bend brass tubing without kinking is to pack the tube with common table salt before bending. Winding around a dowel or rod of the desired diameter works well. The salt can then be recycled onto your dinner salad.

**April
Meeting
Notice:**
(Third Tuesday of the Month)
Tuesday, Apr. 16th
7:00 P.M.
Centennial Lakes
Centrum Building

Commodore:	Jeff McCabe
Vice Commodore	Dave Bros
Vice Commodore	Doug Campbell
Vice Commodore	Mikio Kirihara
Vice Commodore	Dan Proulx
Treasurer	Gary Phillips
Newsletter Editor	Jim Smith

EDINA MODEL YACHT CLUB
CENTENNIAL LAKES CENTRUM
7499 FRANCE AVENUE SOUTH
EDINA, MN 55435

HobbyTown USA
Build Your Dreams!



Radio Controlled
Boats - Cars - Planes
Sports Cards
Trains - Rockets -
Kites
Tools - Paints
Models
& Much More

OPEN

M - F 10 TO 9

SAT 10 TO 6

SUN 11 TO 5

7Hi Center, Hwy. 7 & 101

4818 S. Hwy 101

Minnetonka, MN. 55345

470-7474

First Class