



# SAIL & SCALE

NEWSLETTER OF THE EDINA MODEL YACHT CLUB

September 1996

Volume 5, Number 9

**Commodore's Corner:** Please come prepared for the business at hand...see the notice below. *Jeff*

**Nomination of Officers:** Nominations for the position of Commodore, and separately for the various Board positions will be accepted from the membership at the club meeting on September 17th.

Carefully consider the person or persons whom you would like to see leading our organization during the next twelve months. We would like to have at least two members interested in the position of Commodore to accept nomination, and five or more willing to accept for the four Board member positions. Any current member may be nominated to either or both of these positions. Although a member may nominate himself or herself, all nominations do require a second. If your nominee is unable to attend the meeting, please determine his or her willingness to serve prior to placing their name in nomination. All members in good standing are eligible for nomination (The present Commodore, having served two consecutive terms on the Board, is ineligible).

Those accepting nomination will be asked to submit a short, written position statement on a form which will be distributed at the meeting, and return it to the newsletter editor prior to October 1st. Statements will be published, along with the ballots, in the October newsletter.

Mailed in ballots will be counted at, and new officers introduced at the Dry Dock Party in November. Term of office will run until the Dry Dock Party of 1997, or December 31, 1997, whichever occurs first.

**What's The Meeting?:** As noted above, Nominations. With that in mind, please consider the following verse:

MY CLUB

What kind of club would my club be,  
If all of the members were just like me?  
You should thoughtfully ask yourself that question.  
If not, perhaps it's a swell suggestion.  
You can sit by the fireside, smoking your pipe,  
Find fault with the officers, censure and gripe.  
Or you can be one who is always on call,  
Both ready and willing to carry the ball.  
To your fellow members you will soon be known,  
As a true loyal worker, or else a drone.  
You can take up the challenge, or you can refuse,  
To take part beyond paying your dues.  
You can stand on the sidelines, or jump in and play,  
attend every meeting or just stay away.  
You can visit his home when a member is ill,  
Or leave all the calling to Joe or to Bill.

Whatever your talent, some job you can do,  
So say to yourself as you pass in review,  
"What kind of club would my club be,  
If all of the members were just like me?"

Well! What do you say?

Is it time for YOU to step forward?

**Acknowledgment:** The Club received the following note from Jackie Evans Doncavage, Adaptive Recreation Director for the City of Edina:

"Thank you so much for welcoming Edina Adaptive Recreation for an evening with the Model Yacht Club. Everyone had a great time when we joined you last month. Please pass along my sincere thanks to all of your members who were involved with the event. Thanks to your patience and kindness, everyone left feeling successful!

Thanks again! I look forward to working with you again next summer!"(signed) *Jackie*

**For Sale:** Member, Mary Miller has a ready to sail *Fairwind*, complete with radio and two sets of crystals available for purchase at \$325...or best offer. Give her a call [REDACTED] for additional details.

Jeff McCabe needs room! To ease the clutter he will part with his Kyosho *Hydrojet* (no radio) for \$50, and his short haul 1:24 scale river tow boat, also sans radio will go to the first bearer of another \$50. Jeff can be reached at [REDACTED]

**Congratulations:** New member, Kirk Brust made a respectable showing at the Minnesota State Fair and brought home a ribbon along with his model of the *Edmund Fitzgerald*.

Tony Johnson made the trek to Appleton, WI to compete in the "Stecker Invitational" *Fairwind* regatta. Although he missed the first heat, he still managed to pull off a second place for the event! Amazing!

**Untrue!:** One member has stated publicly that his reason for attempting to form a new club in another suburb was your editor's refusal to publish a schedule of his events in this newsletter.

Upon direct confrontation by me, he denied that remark and stated instead that it was the Board of Directors who refused to allow the publication. I have spoken with all members of the Board, and each has denied knowledge of any such refusal.

If nothing else, this organization is run by a group of open and honest people. When the rumors are flying, please ask the Commodore or any Board member for the "straight" word. Do not trust rumors! *Jim Smith*

**Membership Meeting, 8/20/96:** 22 members in attendance. Jeff McCabe announced that at the September meeting, we would hold nominations for Commodore and Board members for the coming year. Dave Bros announced the Big E event upcoming and explained how the event would be held. Asked for volunteers and Carl Bottemiller volunteered to help. Doug Campbell announced the second electric regatta on Sept. 8th for the south pond. All electric boats welcome. Marblehead regatta announced for Sept 15th. Mickey Kirihara will head up the dry dock party and asked for

volunteers. Jim Smith had a deal on transmitter bags that a logo could be placed on. Doug Campbell and Dan Proulx discussed the fast electric regatta they attended in Chicago. Jim Smith announced a boating event in St Louis on Sep 28-29 The 8th annual RC boat regatta - sponsored by the St. Louis admirals. A question was raised about radio frequency protocol. Jeff explained that the club requests one displays their frequency on their radio. Several technical presentations followed the meeting on building techniques and radio information.  
*Doug Campbell*

### Schedule of Upcoming Events

	Every Sunday	Open Boating	4:30PM - 9:00PM
	Every Tuesday	Open Boating	5:30PM - 9:00PM
	Every Thursday	Open Boating	5:30PM - 9:00PM
Sept.	15th (Su)	Marblehead Regatta	South Pond 2:30PM - 4:30PM
	17th	Memb. Meeting (Nominations)	Centrum Bldg. 7:00PM - 8:00PM
	19th	Light Up The Lake	South Pond 7:00PM -10:00PM
	28th, 29th	St. Louis Admirals Regatta	Union Station All Day - Both Days
Oct.	13th (Su)	Columbus Day Regatta	North Pond 1:00PM - 4:30PM
	15th	Membership Meeting	Centrum Bldg. 7:00PM - 8:00PM
Nov.	9th (Sa)	Dry Dock Party	Centrum Bldg. 6:00PM -11:00PM
	19th	Memb. Meeting (Swap Meet)	Centrum Bldg.(tentative) 7:00PM -10:00PM

**Scale Regatta:** The St.Louis Admirals Model Boat Club will hold their eighth annual Regatta over the weekend of September 28th (10:00AM - 4:00PM) and 29th (10:00AM - 3:00PM) at Union Station in St. Louis, Missouri. First, Second and Third place trophies will be awarded in nine classes: Pleasure Craft / Sailboat, Commercial Vessel, Work Boat, River Work Boat, Military & Government (under 150'), Military & Government (over 150'), Runabout, Miniature, Scratch Built. There should be a class there to please just about anyone. Additionally, Best of Show, Skipper's Choice and Admirals Prize awards will also be given. A flyer will be available at the September meeting or you can call any of the following St.Louis club members for more information:

Tom O'Deli [redacted] Gary Harmon [redacted] John Midkiff [redacted] Don Tashner [redacted]

**Contest Report...Times Two:** On August 3 & 4, Dick Edge, myself and our wives entered the model boat contest in Manitowoc, Wisconsin. We had no idea what to expect, and after two days of lectures and discussions, you could sense that they were experts. There were 40 boats entered. Dick got awards for his catamaran and cruiser, I got an award for my steamboat. Unfortunately, the fish tug got nothing.

Typically, their boats were scratch built, all blocks, etc. were hand machined, and when it was all done, they built a glass case to go around it. It was fun to be around these people for two days.

They have the same problem we do, how to get rid of the models...but theirs are worth a lot more in time and money. In my case, I drove up to Gills Rock and gave my tug to the local fishing museum.

Considering that between Dick and I we had four of the five radio controlled models entered, it was mostly a scale model contest, but there certainly were some beautiful models. *Glenn Anderson*

The Wisconsin Maritime Museum 20th annual Model Ship and Boat Contest was held on August 3rd and 4th with two EMYC members in attendance. Glenn Anderson and his wife, Hildegard plus Dick Edge and his wife, Doris, made the trip. It is a six and one-half hour drive if you leave at four in the morning plus a breakfast stop in Wausau, so it makes for a very long day.

Glenn entered his Great Lakes fishing boat, *Hildegard*, and his paddle oar steamer the *John Fitch*, and received a merit award for the latter. Dick entered his *Trojan* Cruiser and *Wildcat* Catamaran and received merit awards for both in the Novice class. There were some twenty-five contestants who entered a total of forty-four vessels, of which only eight were of operating class with the balance made up of scratch or modified kits of static class with some in glass showcases.

A Saturday symposium was held on modeling and was hosted by Reverend Bob Thomson and Mr. Frank White. Awards and pictures were taken on Sunday afternoon by Model Ship Builder Magazine and the Maritime Museum. The awards were based on a historical account paper, a construction paper and overall appearance of the model.

Manitowoc is a city of thirty-two thousand people with lots of flower gardens, a producer of aluminum ware and home of the Lake Michigan carferry, the *SS Badger*. We recommend the Inn on Maritime Bay for lodging. It has a good pool and a fine dining room with a view of the lake.

The hombound trip on Monday required a stop in Green Bay to see the Green Bay Packers football team work out and a stop in Pulaski, WI to the Carver Boat Factory, the parent to the *Trojan* Cruiser of Sarasota, FL. In all, it made for an eventful weekend. (Next year's Contest is scheduled for August 2 & 3, 1997) *Dick Edge*

**Dry Dock Party:** Party time is coming up again! Let's make this the best attended event of the year! Keep the evening of Saturday, Nov.9th open and call either Paul Olsen [redacted] or Mikio Kirihara [redacted] prior to Oct.27th to make your reservation. (It would be nice if you'd volunteer your services, too. Ed.)

**Deadline:** Please submit items for the October newsletter by the 1st of the month. Special thanks this month to Glenn, John, Dick and Dick for their input!!

**Speed vs. Duration:** Recently, Dick Kjellberg had a friend draw him a wiring diagram for a series (speed), parallel (duration) battery arrangement for use in his fast electric boat. The diagram showed two separate switches which appeared to me to be easily incorporated into one. I consulted John Bishop, our resident wiring wizard, and he consented to redraw the circuit using only one switch, albeit a double pole double throw (DPDT) unit. I also asked John to draw up a circuit that would duplicate Tom O'Dell's "Hyper Thrust" device, (Astro 40, 12 volt lead acid battery and a seven cell Ni-Cd booster battery for a total of twenty volts). If you missed the performance of that gadget back in April, it would be worth a trip to St. Louis just to see it in action.

The series/ parallel circuit should use two batteries of the same voltage and mAh size, while the second battery in the 'hyper thrust' version can be of any size since it is only used in series and then, only intermittently.

Two cautions come to mind. Use switches of high capacity, since large current surges will take place when either of these devices is activated. Arcing within the switch will contribute to a short life span and a higher capacity switch will last longer. Second, make certain that the speed control and/or battery eliminator circuit in use can handle the sum of both battery voltages added together and that the speed control can also manage the high amperage which is inherent in a higher voltage situation. It can be very expensive to replace fried MOSFETs!

Of course, you will also need a spare radio channel and additional servo to operate either of these devices.

Series / Parallel circuit - using one double-pole, double-throw (DPDT) switch

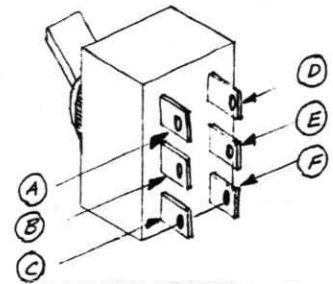
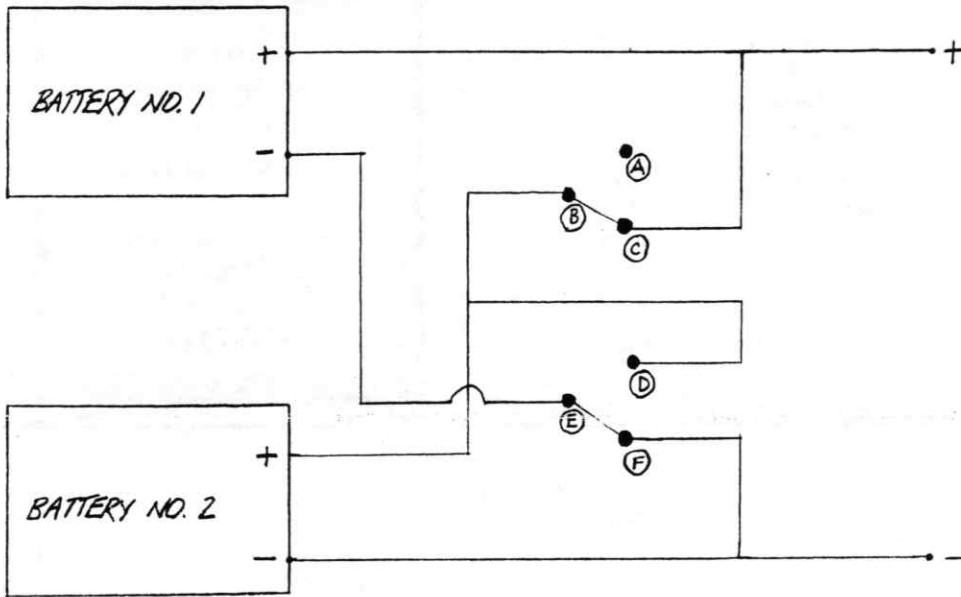

DPDT SWITCH

Tom O'Dell's, "hyper thrust" circuit - using one single-pole, single throw (SPST) switch

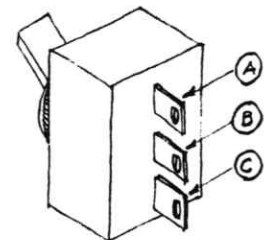
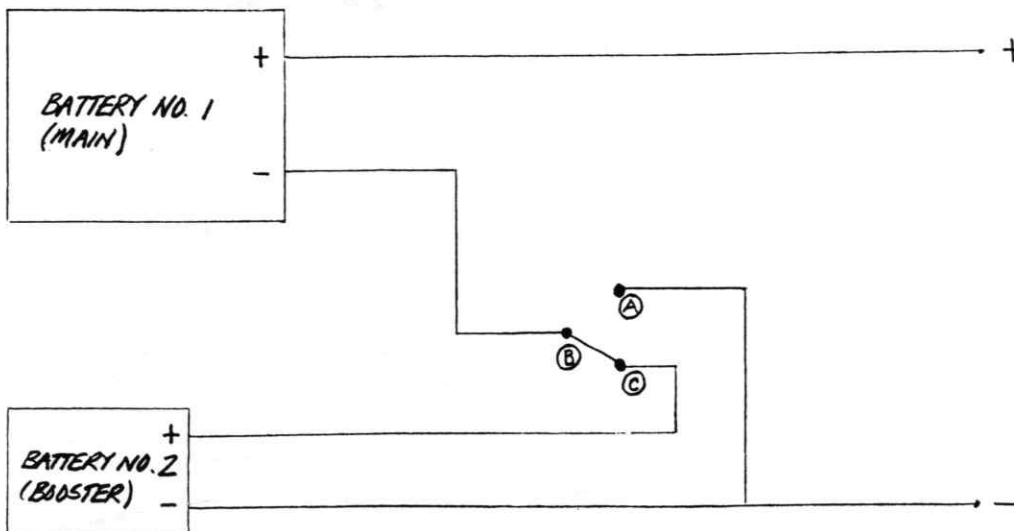

SPST SWITCH

# September Meeting Notice:

(Third Tuesday of the Month)

**Tuesday, Sept. 17<sup>th</sup>**

**7:00 P.M.**

**Centennial Lakes  
Centrum Building**

Commodore:	Jeff McCabe
Vice Commodore	Dave Bros
Vice Commodore	Doug Campbell
Vice Commodore	Mikio Kirihara
Vice Commodore	Dan Proulx
Treasurer	Gary Phillips
Newsletter Editor	Jim Smith

**HobbyTown USA**

**Build Your Dreams!**



**Radio Controlled  
Boats - Cars - Planes  
Sports Cards  
Trains - Rockets -  
Kites  
Tools - Paints  
Models  
& Much More**

**OPEN**

**M - F 10 TO 9**

**SAT 10 TO 6**

**SUN 11 TO 5**

**7Hi Center, Hwy. 7 & 101**

**4818 S. Hwy 101**

**Minnetonka, MN. 55345**

**470-7474**

**EDINA MODEL YACHT CLUB  
CENTENNIAL LAKES CENTRUM  
7499 FRANCE AVENUE SOUTH  
EDINA, MN 55435**

**First Class**